

X-BAND EXPONENTIALLY-TAPERED HORN ANTENNA

8.2 GHz TO 12.4 GHz

EHA-WR90

KEY FEATURES

- X-band exponentially-tapered horn antenna with symmetric E-plane and H-plane radiation patterns
- Gain from 12 dBi to 15 dBi across the X-band
- Designed to minimize VSWR
- Durable all-metal body (aluminum)
- Professionally designed and hand-tested by engineers in the United States

DESIGN SPECIFICATIONS

- Design: Exponentially-Tapered Horn Antenna
- Operating Frequency: 8.2 GHz to 12.4 GHz
- Polarization: Linear (horizontal/vertical based on orientation)
- Waveguide Size: WR-90
- Flange: UG-135/U
- Body Material and Plating: Aluminum Alloy, Paint
- Length: 2.5 in [63.5 mm]
- Width: 1.8 in [45.7 mm]
- Height: 3.0 in [76.2 mm]



EHA-WR90

PERFORMANCE SPECIFICATIONS

Parameter		Frequency	Min.	Typ.	Max.	Unit
VSWR ¹		8.2 GHz – 12.4 GHz	–	1.4	2.0	–
Gain		8.2 GHz – 12.4 GHz	11.5	13.5	15.5	dBi
HPBW	E-Plane	8.2 GHz – 12.4 GHz	30	40	48	deg.
	H-Plane		30	40	48	
Impedance		–	50			Ω
Connector		–	WR-90 UG-135/U			–

¹ Specification when using the AntenX SMA-WR90 coax to waveguide adapter.

X-BAND EXPONENTIALLY-TAPERED HORN ANTENNA

8.2 GHz TO 12.4 GHz

EHA-WR90

TYPICAL PERFORMANCE

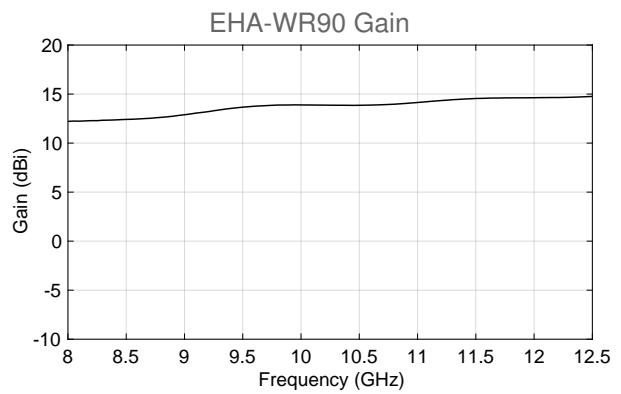
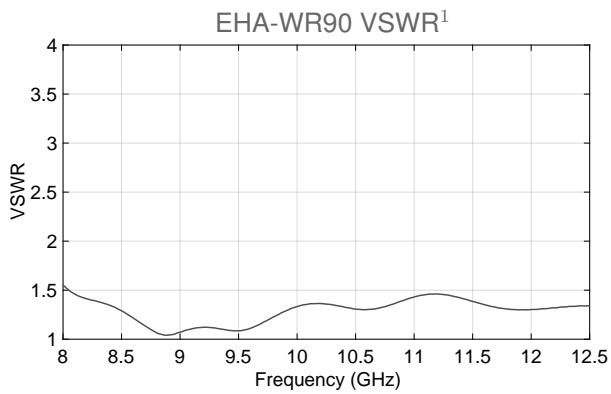

¹ Measured using an AntenX SMA-WR90 coax to waveguide adapter

EHA-WR90 Normalized Radiation Patterns

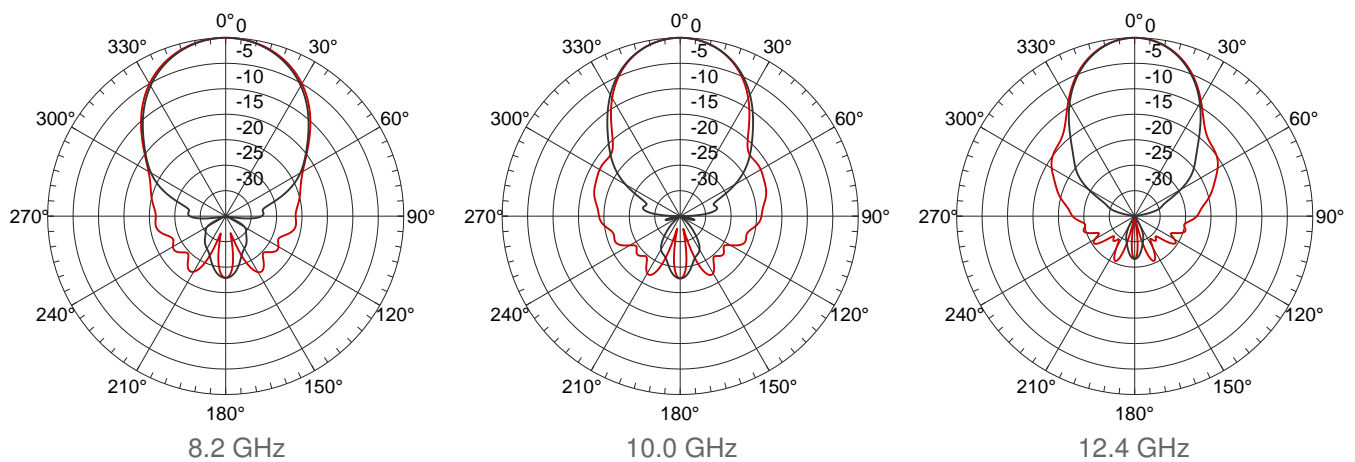

— E-Plane — H-Plane

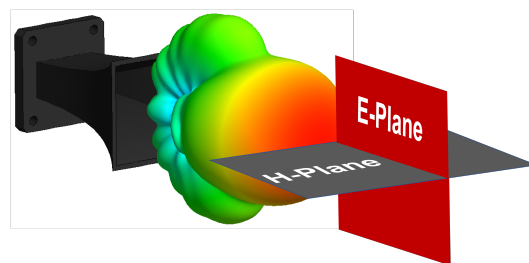

X-BAND EXPONENTIALLY-TAPERED HORN ANTENNA

8.2 GHz TO 12.4 GHz

EHA-WR90

CAD DRAWING

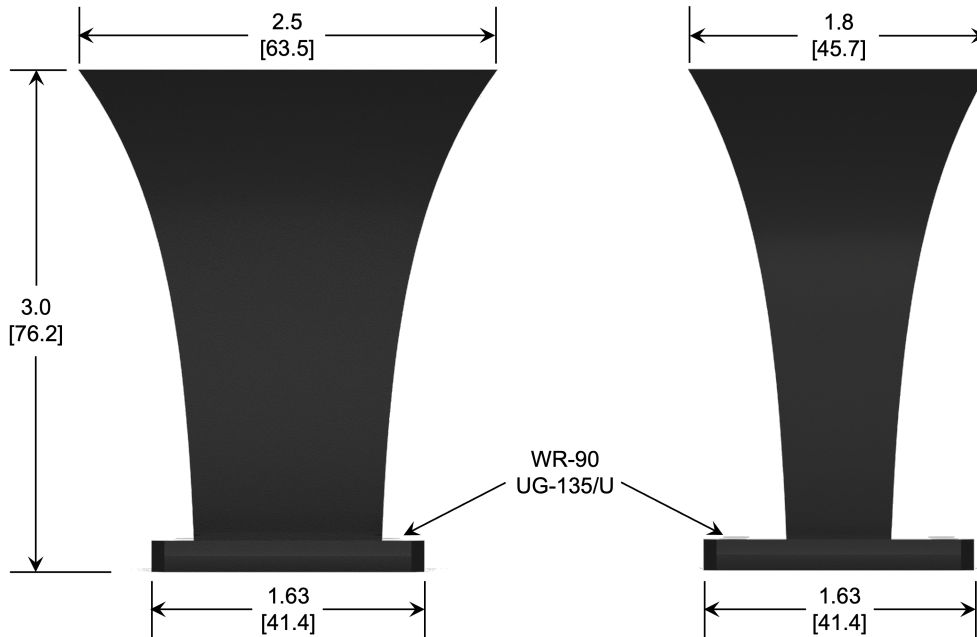

NOTES:

1. UNLESS OTHERWISE SPECIFIED ALL DIMENSIONS ARE NOMINAL
2. DIMENSIONS ARE IN INCHES [mm]
3. ALL SPECIFICATIONS ARE SUBJECT TO CHANGE WITHOUT NOTICE AT ANY TIME