

KU-BAND OPEN-ENDED WAVEGUIDE PROBE ANTENNA

12.4 GHz TO 18.0 GHz

OEWG-WR62

KEY FEATURES

- Ku-band open-ended waveguide probe antenna
- Typical gain of 7 dBi and designed to minimize VSWR
- Durable all-metal body (aluminum)
- Tapered ends to minimize diffraction effects
- Professionally designed and hand-tested by engineers in the United States

DESIGN SPECIFICATIONS

- Design: Rectangular Open-Ended Waveguide Probe
- Operating Frequency: 12.4 GHz to 18.0 GHz
- Polarization: Linear (horizontal/vertical based on orientation)
- Waveguide Size: WR-62
- Flange: UG-1665/U
- Body Material and Plating: Aluminum Alloy, Paint
- Length: 1.31 in [33.3 mm]
- Width: 1.31 in [33.3 mm]
- Height: 4.0 in [101.6 mm]

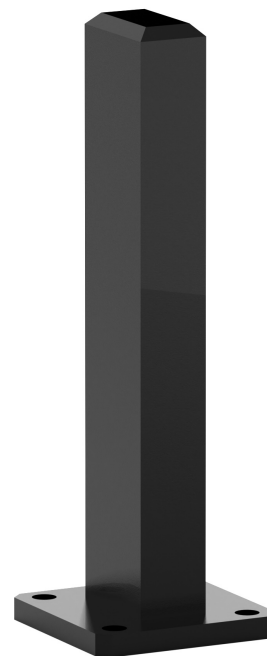

OEWG-WR62

PERFORMANCE SPECIFICATIONS

Parameter		Frequency	Min.	Typ.	Max.	Unit
VSWR ¹		12.4 GHz – 18.0 GHz	–	1.6	3.0	–
Gain		12.4 GHz – 18.0 GHz	3.5	7.0	10.0	dBi
HPBW	E-Plane	12.4 GHz – 18.0 GHz	45	85	110	deg.
	H-Plane		35	60	80	
Impedance		–	50			Ω
Connector		–	WR-62 UG-1665/U			–

¹ Specification when using the AntenX SMA-WR62 coax to waveguide adapter.

KU-BAND OPEN-ENDED WAVEGUIDE PROBE ANTENNA

12.4 GHz TO 18.0 GHz

OEWG-WR62

TYPICAL PERFORMANCE

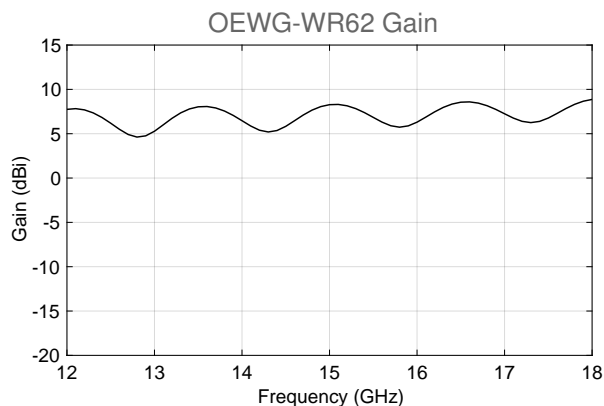
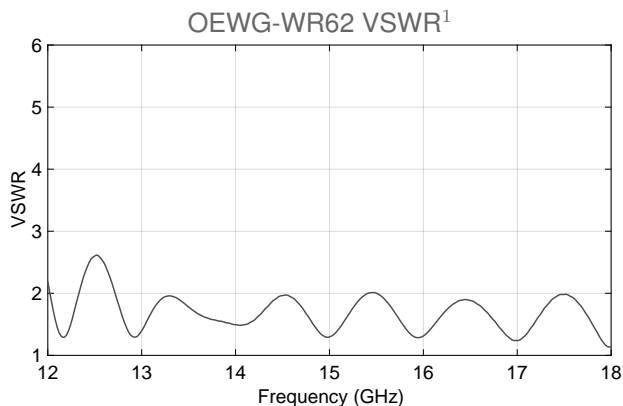

¹ Measured using an AntenX SMA-WR62 coax to waveguide adapter

OEWG-WR62 Normalized Radiation Patterns

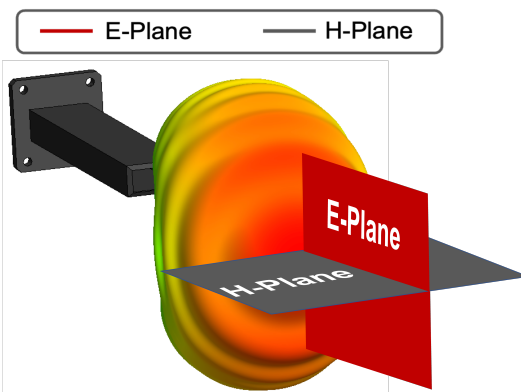
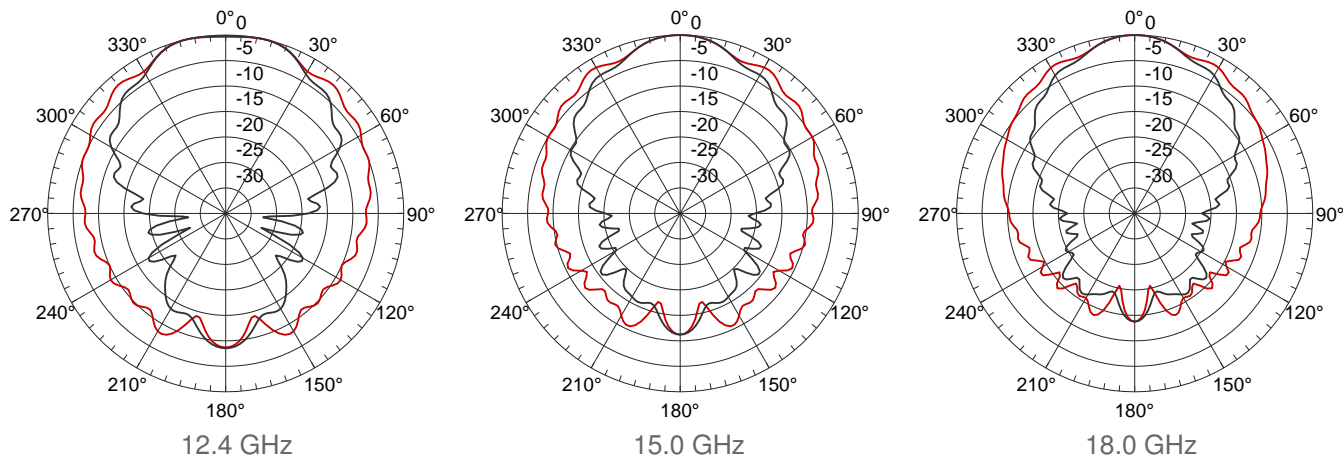

KU-BAND OPEN-ENDED WAVEGUIDE PROBE ANTENNA

12.4 GHz TO 18.0 GHz

OEWG-WR62

CAD DRAWING

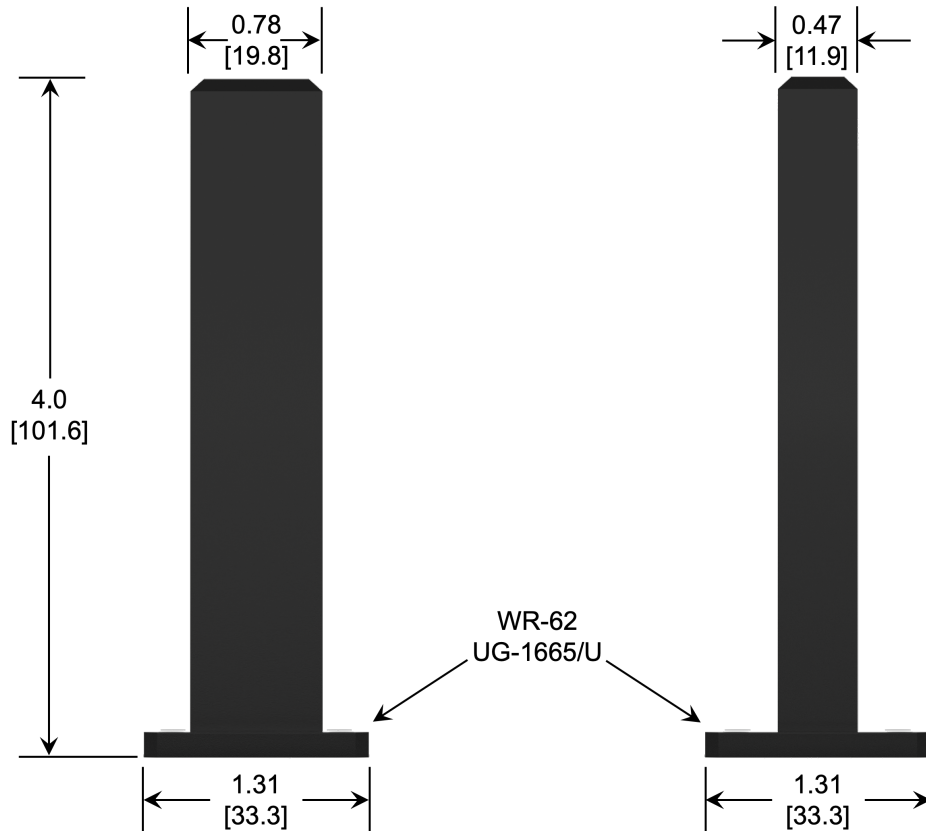

NOTES:

1. UNLESS OTHERWISE SPECIFIED ALL DIMENSIONS ARE NOMINAL
2. DIMENSIONS ARE IN INCHES [mm]
3. ALL SPECIFICATIONS ARE SUBJECT TO CHANGE WITHOUT NOTICE AT ANY TIME