

BROADBAND SPIRAL ANTENNA

2 GHz TO 18 GHz

SPIR2000

KEY FEATURES

- Very wide bandwidth from 2 GHz to 18 GHz with a circularly polarized unidirectional radiation pattern
- VSWR typically below 2:1
- Axial ratio typically under 2 dB
- Available in RHCP or LHCP configurations
- Low weight and compact size
- Professionally designed and hand-tested by engineers in the United States



SPIR2000 (Top)



SPIR2000 (Bottom)

DESIGN SPECIFICATIONS

- Design: Cavity-backed spiral antenna
- Operating Frequency: 2.0 GHz to 18.0 GHz
- Polarization: Right-hand circular or left-hand circular
- Connector: SMA Female
- Construction: Anodized aluminum cavity with PCB spiral
- Mounting: #10-24 screw holes (see diagram on page 6)
- Length: 2.5 in [63.5 mm]
- Width: 2.5 in [63.5 mm]
- Height: 1.0 in [25.4 mm] (not including SMA connector)
- Weight: 4 oz [115 g]

MODELS

SPIR2000-R	RHCP
SPIR2000-L	LHCP

PERFORMANCE SPECIFICATIONS

Parameter	Frequency	Min.	Typ.	Max.	Unit
VSWR	2.0 GHz – 3.0 GHz	–	1.8	2.5	–
	3.0 GHz – 13.0 GHz	–	1.5	2.3	
	13.0 GHz – 18.0 GHz	–	1.8	2.8	
Gain	2.0 GHz – 3.0 GHz	-6.0	-1.0	2.5	dBic
	3.0 GHz – 4.0 GHz	-1.0	2.5	5.0	
	4.0 GHz – 18.0 GHz	1.0	4.0	7.5	
Boresight Axial Ratio	2.0 GHz – 3.0 GHz	1.5	2.5	3.9	dB
	3.0 GHz – 16.0 GHz	0.2	1.0	3.0	
	16.0 GHz – 18.0 GHz	0.8	2.0	3.6	
HPBW	2.0 GHz – 18.0 GHz	55	80	120	deg.
Input Power	2.0 GHz – 18.0 GHz	–	–	10	W
Impedance	–	50			Ω
Connector	–	SMA (female)			–

TYPICAL PERFORMANCE

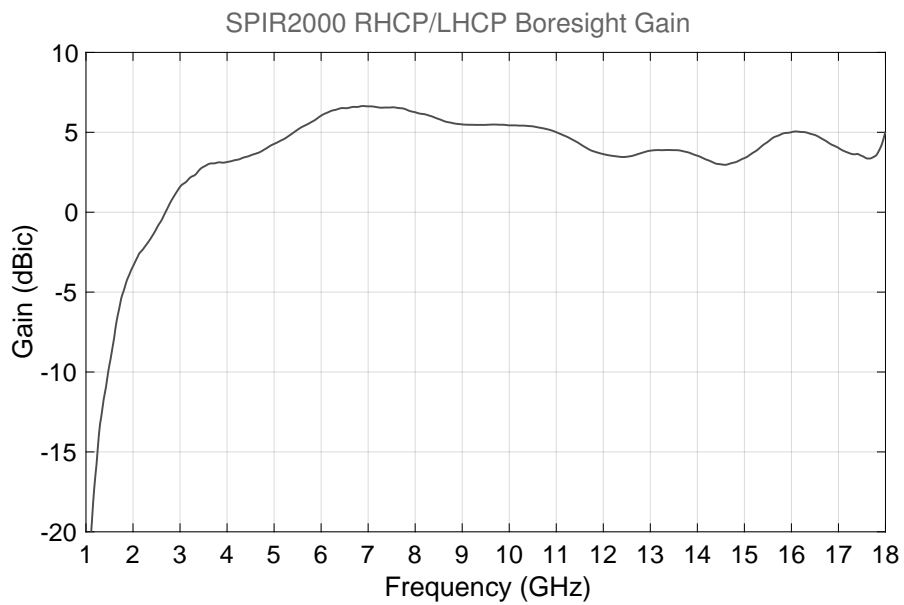
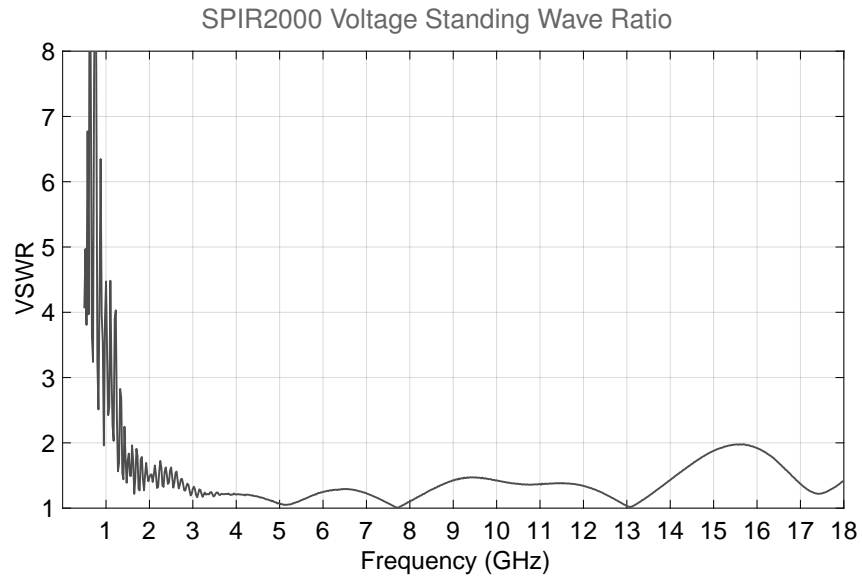

TYPICAL PERFORMANCE (CONT.)

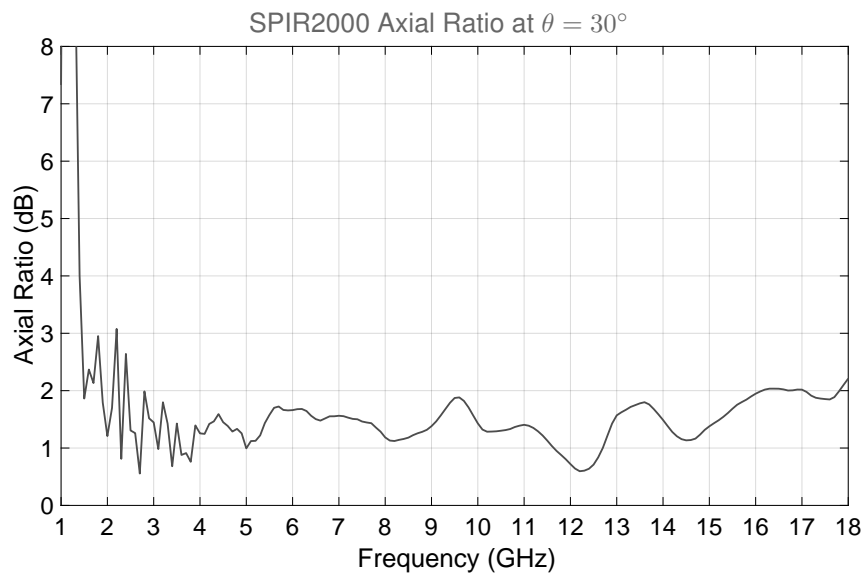
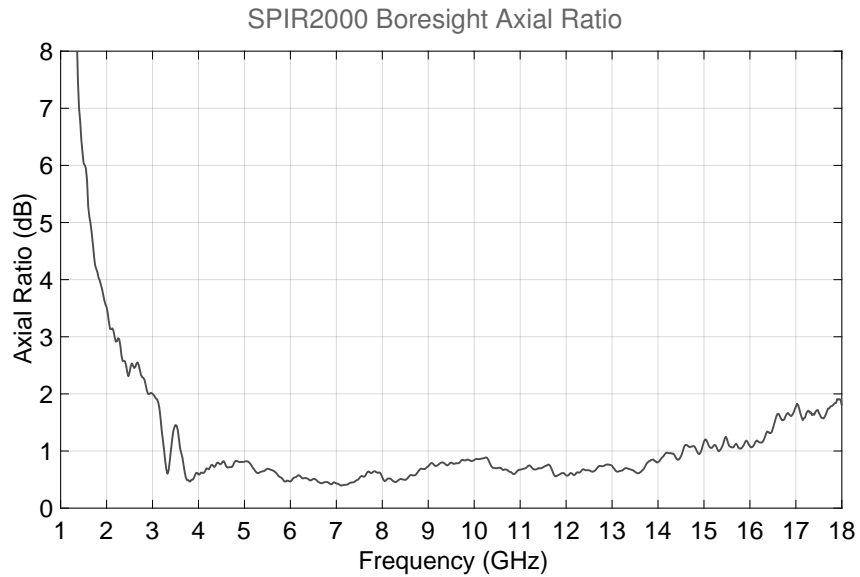

TYPICAL PERFORMANCE (CONT.)

SPIR2000 Normalized Radiation Patterns

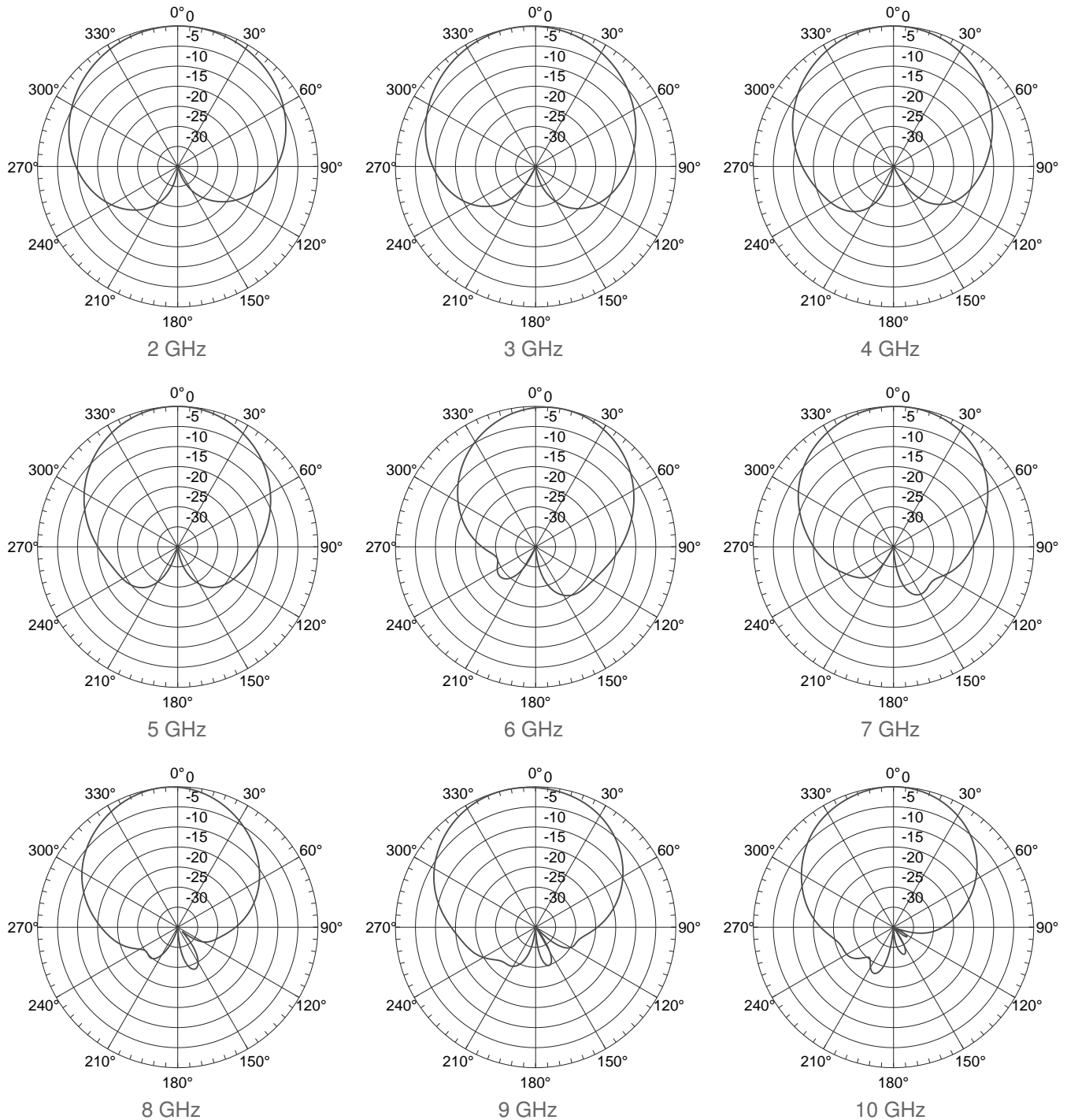

TYPICAL PERFORMANCE (CONT.)

SPIR2000 Normalized Radiation Patterns

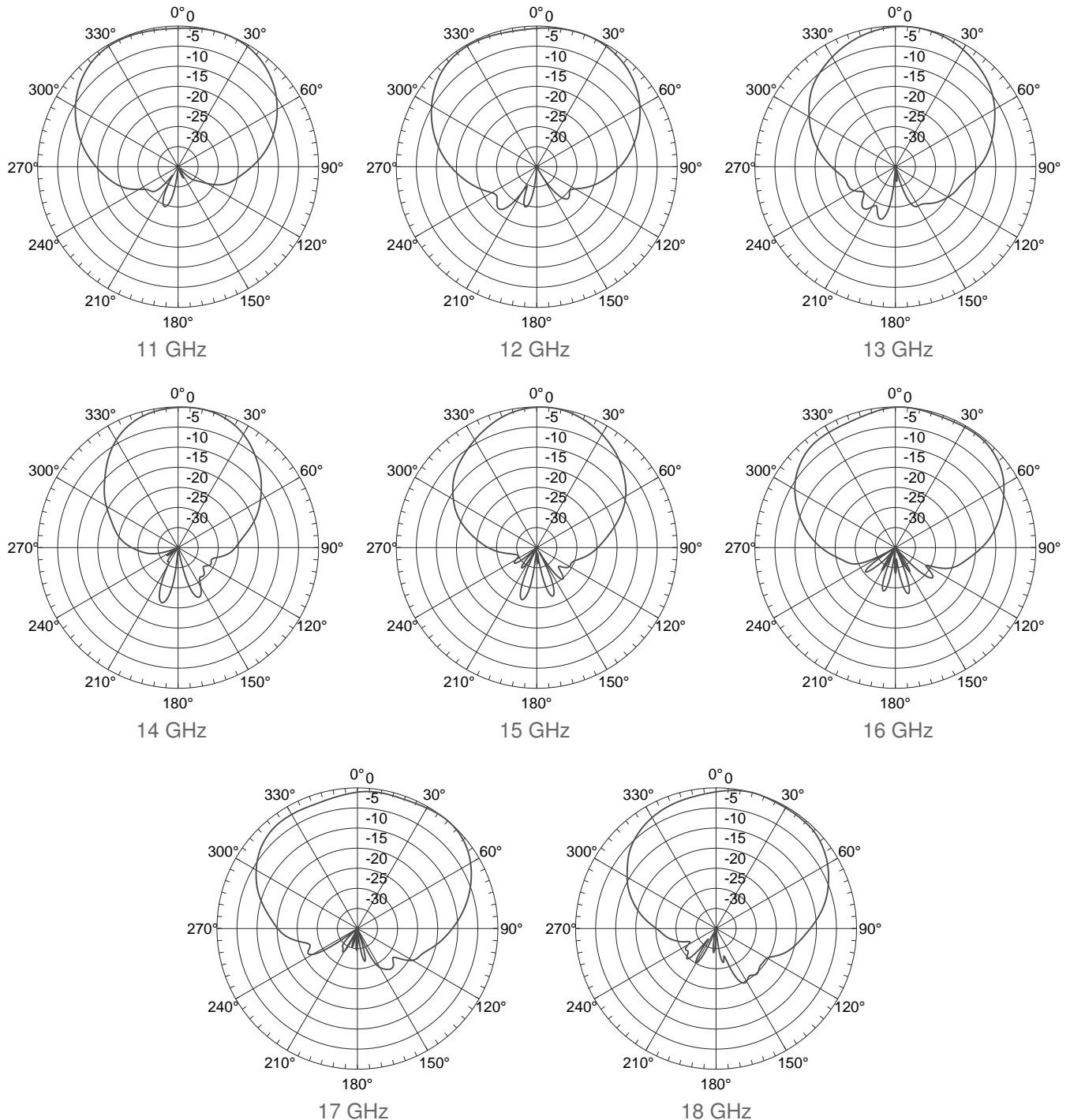

CAD DRAWING

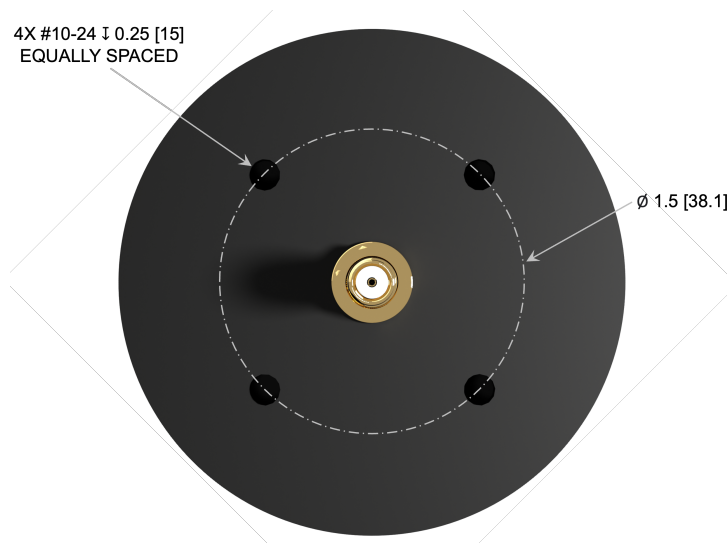
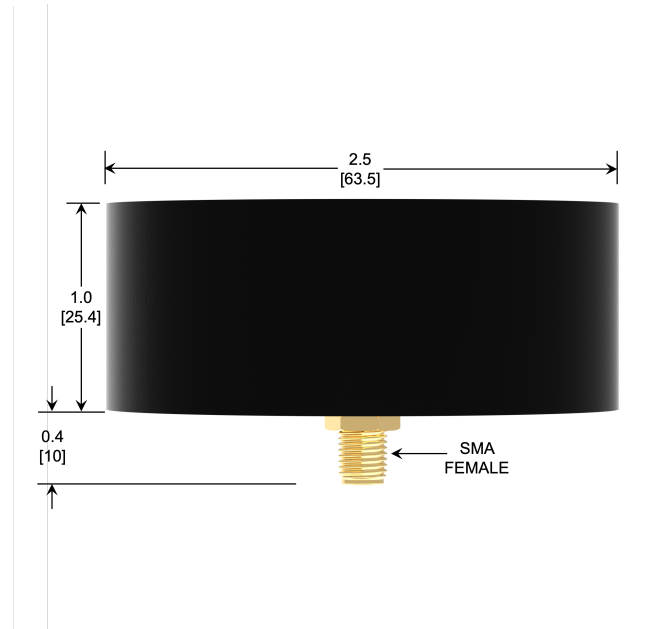
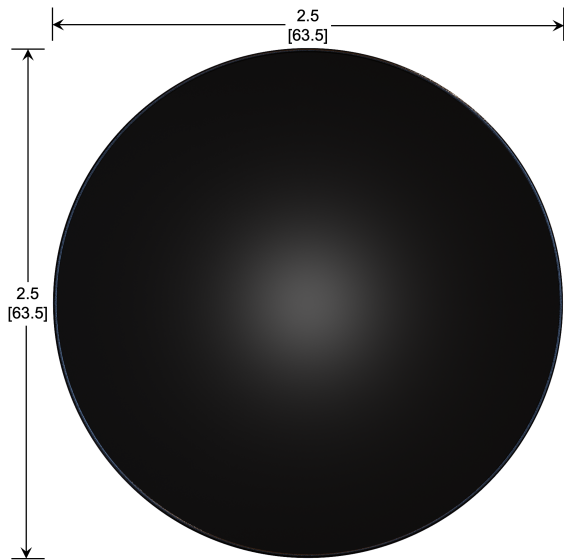

NOTES:

1. UNLESS OTHERWISE SPECIFIED ALL DIMENSIONS ARE NOMINAL
2. DIMENSIONS ARE IN INCHES [mm]
3. ALL SPECIFICATIONS ARE SUBJECT TO CHANGE WITHOUT NOTICE AT ANY TIME